

FISHER®

MANUFACTURING COMPANY

Commercial Faucets Since 1936

www.fisherfaucets.com 1-800-421-6162



OPERATION & MAINTENANCE MANUAL
76057 Faucet

www.fisherfaucets.com

1900 South O Street, Tulare, CA 93274

Phone (800) 421-6162 Fax (800) 832-8238

AC or Battery Powered Sensor Operated Faucet

The 76057 faucet is a piston operated, wall mounted sensor faucet that provides a vandal resistant, no touch solution that promotes better hygiene and energy savings. Using a patented gooseneck design, the 76057 faucet is ideal in clinics, hospitals, and manufacturing facilities for scrub stations.

- **ADA Compliant.** Meets all barrier free codes
- Conserves water and energy
- Easily installed in new or retrofit applications
- Competitively priced for today's commercial market
- Promotes cleanliness & hygiene
- Proven craftsmanship and reliability



Features:

- **ACCU-SENSE** adjustable sensor eyes.
- Chrome plated, solid brass construction.
- Wall mountable, waterproof control box with armored, vandal resistant control and power cables.
- Preset/adjustable sensor range of 6" - 30" for various installation requirements.
- Standard automatic time-out feature. Preset at 30 seconds, but adjustable to 10, 30, or 60 seconds. Prevents accidental sink overflow.
- Shut-off delay is adjustable from 1 (preset) to 8 seconds.
- Single-hole, wall/splash mounting
- Includes in-line filter with clean-out trap to reduce maintenance costs.
- Standard 6" gooseneck spout and 2.0 GPM or 0.5 GPM Laminar flow control.
- All parts are field-replaceable to ensure quick and easy repair.
- Same faucet-field switchable to AC or battery powered.
- AC with DC backup models automatically switch to batteries during a power outage.
- Slow closing, piston-operated solenoid valve provides reliable and smooth operation without water hammer.
- Superior VSI silicone elastomer piston seals are unaffected by chlorine, chloramines, or ammonia.
- Control module allows a unique self-check of all electrical components.
- No-touch system enhances hygiene in medical, institutional, food service industries, etc.

Fisher Manufacturing Automatic Faucets

76057

Wall Mounted / Non-Mixing

Meets ANSI/ASME A112.18.1 M-1989

Operation:

1. A continuous, invisible beam is emitted from the sensor.
2. The faucet is activated by placing hands under the spout within the effective range of the beam. Water starts to flow immediately for as long as the user's hands remain in the sensor range.
3. When hands are removed, the water flow stops. The sensor will automatically reset and be ready for the next user.
4. In the battery powered version, a flashing red light will indicate a low battery condition.

Specifications:

Faucet Construction:

- Solid brass, chrome plated

Control Circuit:

- Solid state, AC or battery, switchable

Auto. Time-out:

- Preset at 20 seconds and adjustable to 10, 30, or 60 seconds

Line Purge (request only):

- 2 minute run every 12 hours or 24 hours

Scrub Mode Delay (request only):

- 60, 120, 180 seconds

Sensor Range:

- Preset and adjustable

Shut-off Delay:

- Presets and adjustable from 1-8 seconds

Control Cable:

- Armored, vandal resistant

Solenoid Valve:

- 6V DC, normally closed

- Wattage: 0.4W (idle), 5W (in use)

- Operating Pressure: 5 psi to 125 psi

- 2.0 or 0.5 GPM, Laminar Flow Control

Flow Control:

AC Mode

Power Adapter

Standard Plug-in:

- Input AC 120V 60 Hz or 220V

(UL/CSA)

Power Cable:

- Output DC 12V, 0.8A/Class 2

- Armored, vandal resistant

Optional Multi-Unit Adapter:

- Serves up to 8 faucets

(UL/CSA)

- Input AC 120V, Output DC 12V, 3A

Battery Mode

Battery Powered Models:

- (4) AA Alkaline Batteries

Battery Service Life:

- 400,000 on/off cycles, up to 4 years

Package Includes:

- (1) Faucet with electronic sensor
- (1) Control box w/6V DC solenoid

- (1) 12V DC plug-in power adaptor
- (1) In-line filter with clean-out trap
- (1) 18" Flex, S.S. supply tube, 3/8"
- (1) 6" Gooseneck Spout
- (1) Mounting hardware
- (1) 2.0 GPM Flow Control
- (4) AA Alkaline batteries
- (1) Battery holder

Dimensions:

Base Width (Outside Measurement)

2-1/4"

Base Depth

2-1/2"

Faucet Height (Aerator to Base)

8-3/4"

Faucet Height Overall

12-3/4"

Depth (Center of Aerator to Center of Faucet Base)

5-3/8"

Mounting Bolt Length

1-7/16"

Mounting Bolt Pattern

Single-hole mount

76057 (AC Powered)

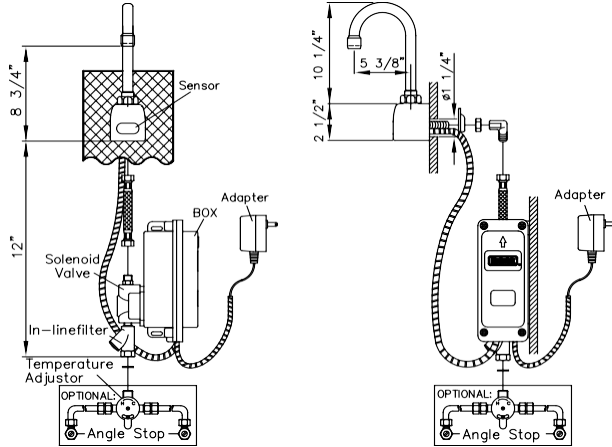

76057 (Battery Powered)

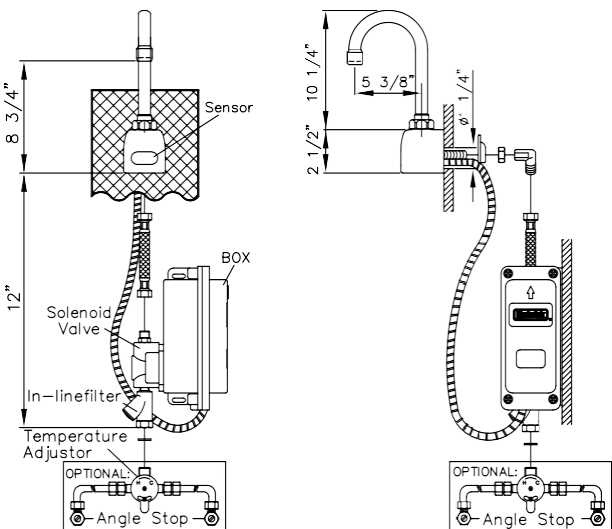

FISHER MANUFACTURING

1900 South O Street

Tulare, CA 93274

800.421-6162 (Phone)

866.832.8238 (Fax)

www.fisherfaucets.com



76076 Series

DC Powered Sensor Operated Mixing Faucet

Installation Instructions

- Prior to installation, thoroughly flush all water lines and replace stop washers, if required.
- To ensure proper operation, "DRY TEST" the faucet by plugging the **Sensor Eye Cable (17)** into the matching connector on the PC board inside of the **Control Box (18)**.
 - AC Powered:** Connect the **Power Adapter (19)** to the PC board inside of the **Control Box (18)**, then plug the Power Adapter into a 120 V AC wall outlet. Place your hand in front of the sensor eye and listen for a clicking sound. If there is no clicking sound, call the factory.
 - Battery Powered:** Properly install new batteries into the battery holder and ensure the battery holder is connected to the PC board. Place your hand in front of the sensor eye and listen for a clicking sound. If there is no clicking sound, call the factory.
- After a successful "DRY TEST", unplug the **Sensor Eye Cable (17)** and **Power Adapter (19)** or battery holder from the PC board.
- Loosen **Flow Control Device (1)** and assemble the **Gooseneck Spout (2)** using the **Split Washers (4)** and **Spout Nut (3)**. Mount the **Gooseneck Spout (2)** onto the **Body (5)**. Feed the **Sensor Eye Cable (17)** through the sink wall and tighten the faucet onto the sink using the **O-Ring (8)**, **Washer (9)**, and **Mounting Nut (10)**. Attach the **90-Degree Elbow (11)** to the **Supply Rod (7)**.
USE TEFLON TAPE ONLY, NO PIPE DOPE
- Reconnect the **Sensor Eye Cable (17)** and **Power Adapter (19)** connections described in STEP #2, making sure the cables are seating in the **Control Box (18)** housing properly.
- Attach the **Compression Fitting (13)** to the **Solenoid Valve (14)** and connect it to the **Elbow (11)** using the **Supply Tube (12)**. Insert the **Nylon Washer (16)** into the swivel nut located on the **In-Line Filter (15)**.
 - Pre-tempered or cold water only:** Use a union fitting (not supplied) to connect the supply line (not supplied) from the supply stop to the **In-Line Filter (15)**.
 - Tempered water:** Attach a mixing valve (not supplied) to the **In-Line Filter (15)**. Connect the supply lines (not supplied) to the mixing valve.
- Turn on water and check for leaks. Plug the **Power Adapter (19)** into a 120V AC outlet (for AC Powered). Push the reset button on the PC Board. Reinstall the cover for the **Control Box (18)** and tighten screws to ensure water resistance. Place hands in front of the sensor eye to activate water flow. Remove hands and the water should stop. If not, refer to the troubleshooting guide or call the factory.
- Periodically clean the filter element located inside the **In-Line Filter (15)**.
- For minor adjustments, refer to the instructions located inside the cover of the **Control Box (18)**.
- IMPORTANT:** The stop valve should never be opened to the point where the water flow exceeds the flow capability of the fixture. The fixture must be able to accommodate the continuous water flow from the faucet in the event of a failure. Should the fixture overflow due to water exceeding the capability of the fixture and/or the drain

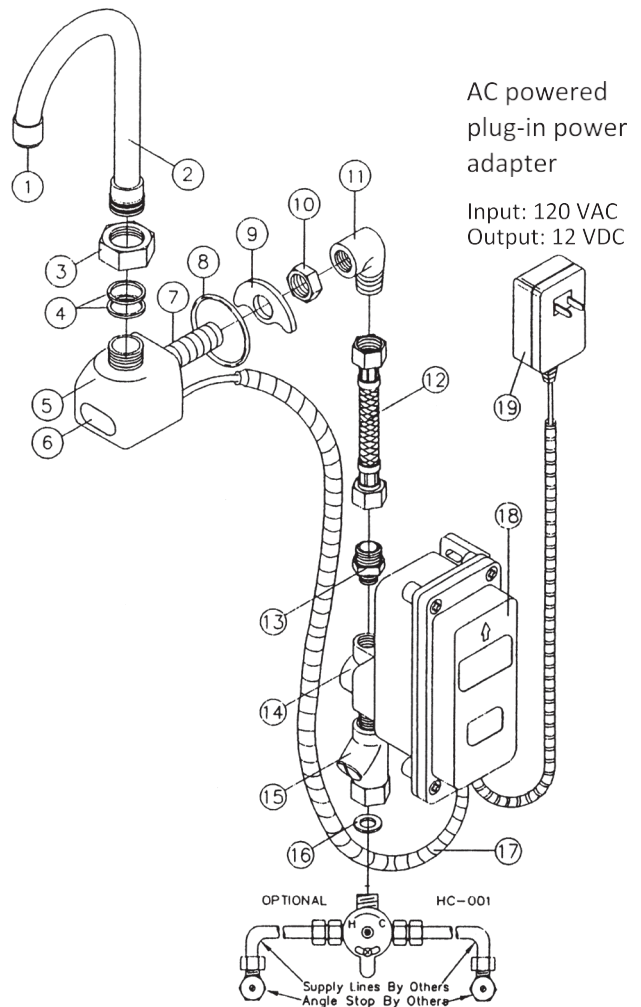

Parts:

1. Flow Control Device	11. 90 Degree Elbow
2. Gooseneck Spout	12. Supply Tube
3. Spout Nut	13. Compression Fitting
4. Split Washer	14. Solenoid Valve
5. Body	15. In-Line Filter
6. LED Sensor Cover	16. Nylon Washer
7. Supply Rod	17. Sensor Eye Cable
8. O-Ring	18. Control Box
9. Washer	19. Power Adapter
10. Mounting Nut	

FISHER MANUFACTURING

1900 South O Street
 Tulare, CA 93274
 800.421.6162 (Phone)
 866.832.8238 (Fax)



www.fisherfaucets.com.com

pipe, Fisher will not be responsible for any damages.

76057

Sensor Operated Mixing Faucet Troubleshooting Guide

Normal Operation: When power is connected, the faucet will immediately perform diagnostic function. You will hear a clicking sound and see lights flash. When the user's hands are placed under the spout, the light will flash once and water will start to flow. Water flow will stop when hands are removed. The red indicator light will flash when the batteries are low.

Turn the manual handle clockwise to increase temperature and counter-clockwise to decrease.

Problem	Possible Cause	To Diagnose	Remedy
Faucet will not turn on:	Water not turned on	Check water supply	Turn water on
	Power supply failure	No light, no clicking: <ul style="list-style-type: none">• Check batteries• Check power adapter	Reinstall or replace batteries/ Replace power adapter
	Low battery	Light continues to flash	Replace batteries
	Electronic PCB / Sensor is defective	No light, no clicking: <ul style="list-style-type: none">• Reinsert batteries• Reattach power adapter	Replace electronic PCB
	Solenoid valve is clogged	Solenoid is clicking but no water is coming out	Clean solenoid
	In-line filter is clogged	Open clean-out trap and check filter screen	Clean or replace filter screen
	Solenoid coil is defective	Insert new batteries or reattach power adapter. Light blinks but no solenoid is clicking	Replace solenoid coil
	Flow control is clogged	Open flow control device and check	Celan the flow control device
Faucet will not shut off, has low glow, or drips:	The solenoid valve is normally closed. Turn off water and activate the faucet. If there is a clicking sound, the solenoid valve is dirty. If there is no clicking sound, then check the solenoid valve. If the faucet is dripping, clean the solenoid valve.		

IMPORTANT: Periodic maintenance is required for smooth and trouble-free operation of this faucet.

For service and inquiry about available repair kits, please call Technical Support at (800) 922- 9883 ext. 103.

Care and Cleaning Instructions:

- **WARNING!** Using abrasive or chemical cleaners **will** damage the chrome or decorative finishes.
- Use only soap and water to clean the finish, then wipe dry with a clean cloth.
- If chemical cleaners are used for other parts of the lavatory, ensure that the faucet is protected from potential contact from those cleaners.

76057

Sensor Operated Mixing Faucet Solenoid Valve Cleaning

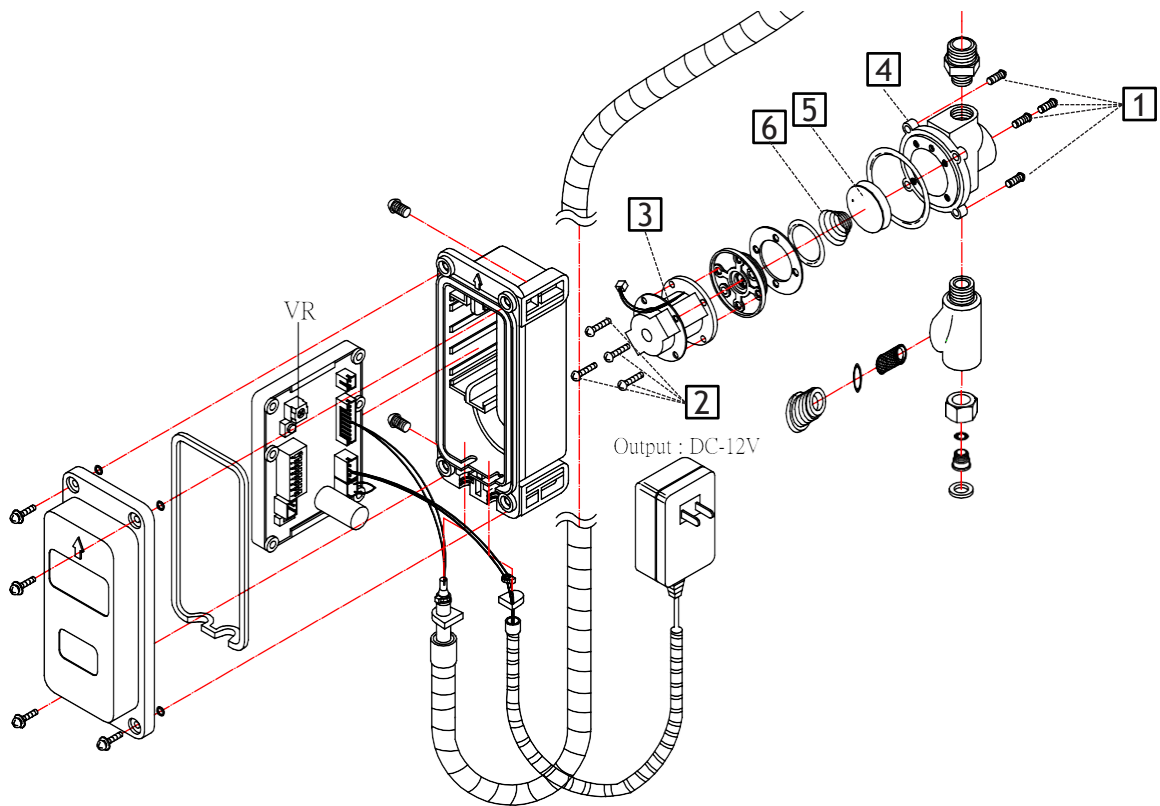

1. Turn off water supply at stop valve.
2. Remove control box (if possible) to gain access to the solenoid valve.
3. Remove four Screws (#1) and separate the valve from the box.
4. Remove four Coil Screws (#2) and separate Coil (#3) from Valve Seat (#4).
5. Clean or replace Control Disc (#5), Disc Spring (#6), Piston, Piston Spring, and check the Piston Sleeve for corrosion.
6. Re-install all parts in same order as the diagram below.
7. Re-install solenoid on the control box and re-mount box in water line.

8. Check and clean Filter Screen (#24) in Filter Body (#22).
9. Reset P.C. Board and make sure solenoid clicks open and thumps closed.
10. Turn on water and check for leaks and proper operation.

(For further questions, please call Tech Support at 1-800-922-9883 ext. 103)

76057

Sensor Operated Mixing Faucet Control Module Settings

Settings Control Dipswitches

Reset Button

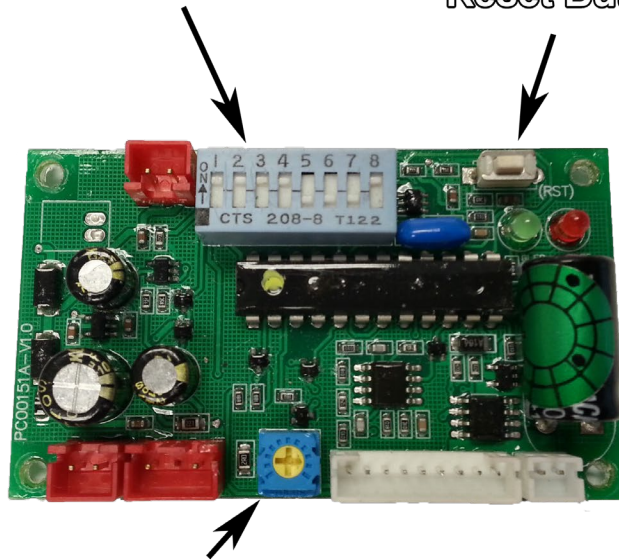

Sensor Length Adjuster

Shut Off Time Delay (After hands are removed)

Sw1	Sw2	Sw3	Delay
On	On	On	1 Sec
On	On	Off	2 Sec
On	Off	On	3 Sec
On	Off	Off	4 Sec
Off	On	On	5 Sec
Off	On	Off	6 Sec
Off	Off	On	7 Sec
Off	Off	Off	8 Sec

Factory Preset

■ = Switch Position

1	2	3	4	5	6	7	8
■	■	■	■	■	■	■	■

Sensor Distance

Sw6	Mode	Distance
On	Std	4" - 12"
Off	Enhanced	10" - 12"

To increase distance, turn adjuster CLOCKWISE

To decrease distance, turn adjuster COUNTER-CLOCKWISE

Automatic Time Off (maximum run time after activation)

Sw4	Sw5	Time Off
On	On	OFF
On	Off	15 Sec
Off	On	30 Sec
Off	Off	60 Sec

Faucet Switch - DO NOT TOUCH

Sw7	Sw8	Mode
On	Off	Auto Faucet

IMPORTANT: Always push the Reset Button after any adjustments