

APPLICATION:

PRODUCT NAME:
**VACUUM BREAKER ANTI-SPILL
SATIN CHROME**

JOB NAME:

_____ SPECIAL CONFIGURATION
(CHECK BASE MODEL AND OPTIONS)

QUANTITY:

ITEM NO.:

MODEL:

14443

OPTIONS OR MODIFICATIONS:

OTHER _____

FEATURES:

- * ANTI-SPILL DESIGN
- * ASSE - 1056 APPROVED

SYSTEM LIMITS

- * TEMP: 33°F MIN. TO 180°F MAX.
- * PRESSURE 8 PSI (MIN) - 150 PSI (MAX)

SHIPPING WEIGHT

- * 2.0 LBS

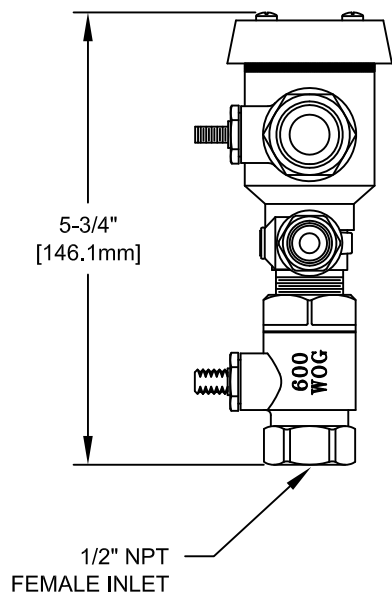
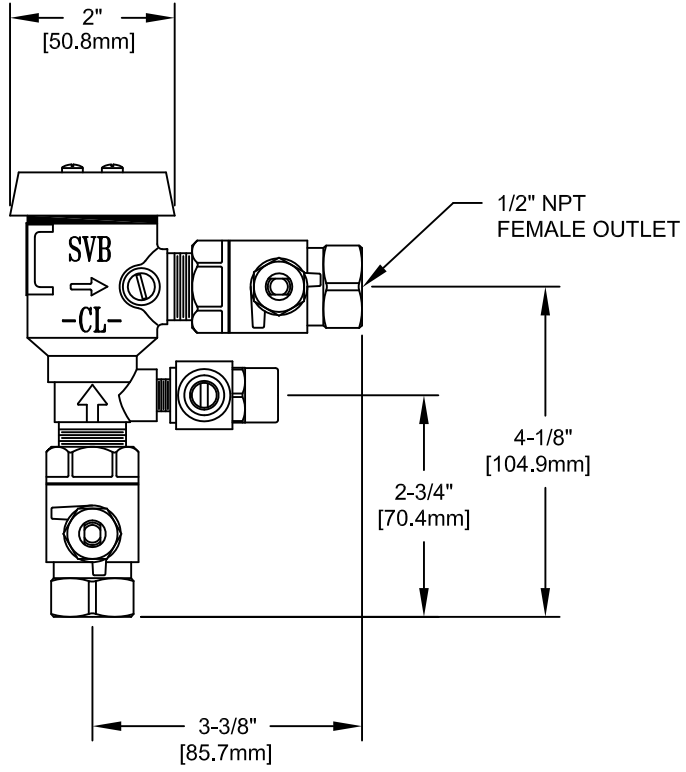

ANSI/A112.18.1M, ANSI/NSF 61.9



FISHER MANUFACTURING COMPANY
TOLL FREE: 800-421-6162 - FAX: 800-832-8238
information@fisher-mfg.com - www.fisher-mfg.com