

# FISHER<sup>®</sup>

FISHER MANUFACTURING COMPANY TOLL FREE: 800-421-6162 - FAX: 800-832-8238  
customer@fisherfaucets.com - www.fisherfaucets.com

PRODUCT NAME:

CHECK VALVE 1/2F X 1/2F

SPEC. CBFBJCV-XX

Customer/Wholesaler:

Date:

Job Name:

Model Specified: 2936-9000

Quantity:

Contractor:

Architect/Engineer:

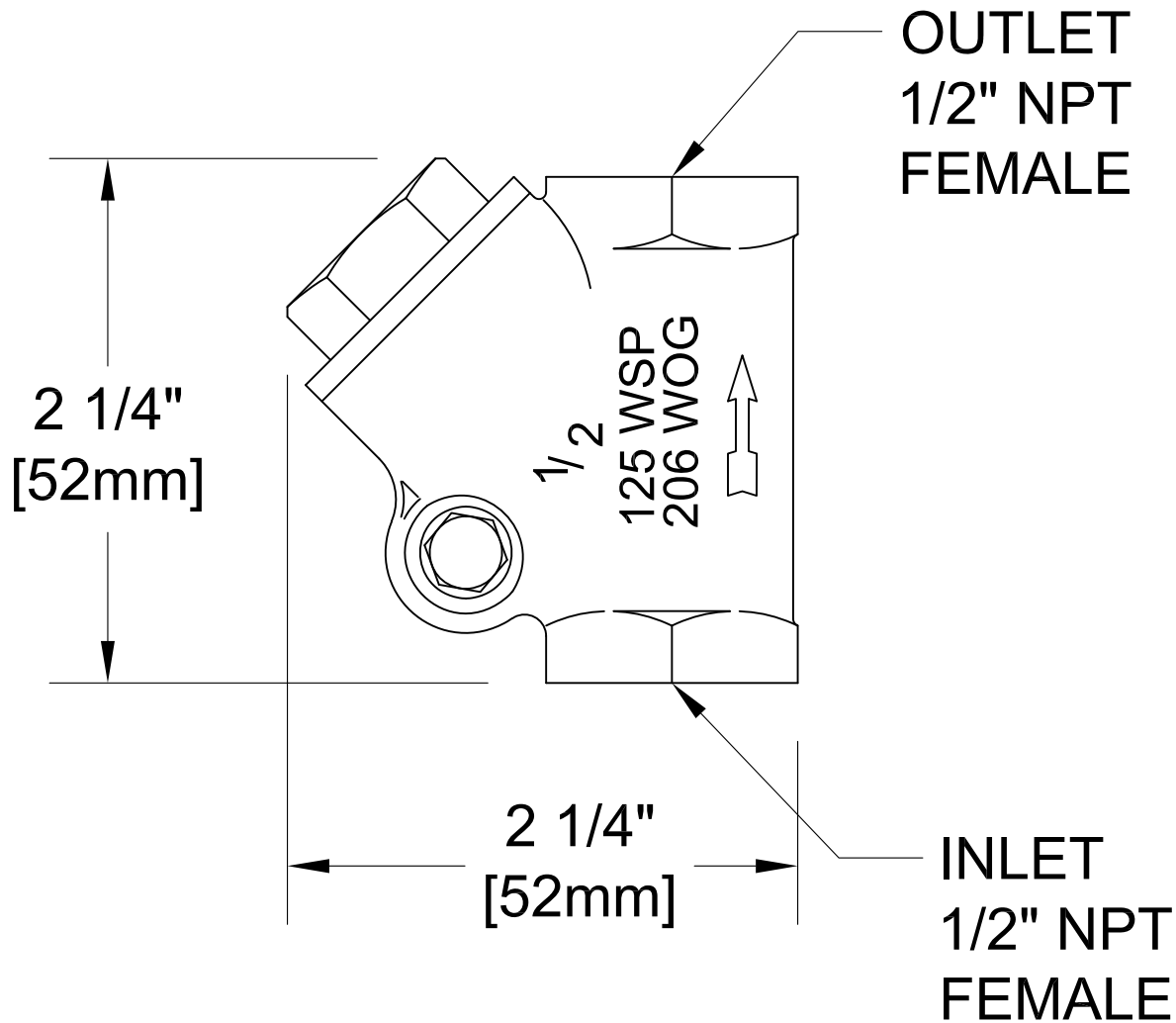

NOTES:

1. Maximum Pressure 400 PSI, Maximum Temperature 100° F
2. Not to be Used for Natural Gas Applications.

PRODUCT SPECIFICATIONS:

CHECK VALVE FOR WATER USE ONLY W/ 1/2" NPT INLET & OUTLET

PRODUCT COMPLIANCE:

ASME A112.18.1 / CSA B125.1  
NSF 61 - Section 9  
NSF 372 (Low Lead Content)

Drawn: DF

Checked: EM

Approved: DF

Date: 02/29/24

Sheet: 1 of 1