

APPLICATION:

PRODUCT NAME: ADPTR GHM X 55/64-27F 304

JOB NAME:

SPECIAL CONFIGURATION  
 CHECK BASE MODEL AND OPTIONS

QUANTITY:

ITEM NO.:

MODEL:

3982-9000 ADPTR GHM X 55/64-27F 304

FEATURES:

\* CONVERTS FEMALE 55/64-27 AERATOR THREAD TO MALE GARDEN HOSE THREAD

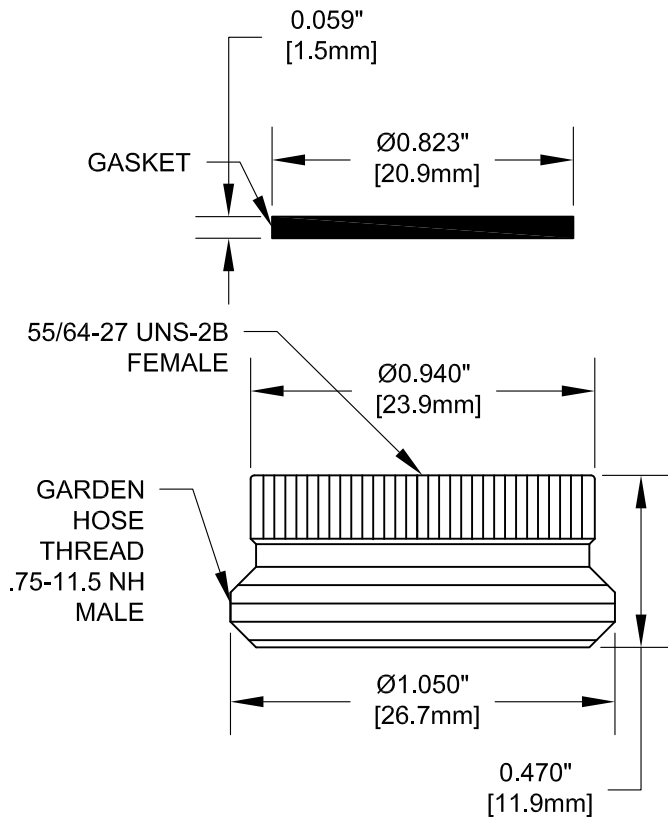

# FISHER

FISHER MANUFACTURING COMPANY  
TOLL FREE: 800-421-6162 - FAX: 800-832-8238  
information@fisher-mfg.com - www.fisher-mfg.com